



TruPunch

The time-
saving
technology

Punching – versatile with strong future potential

Punching encompasses far more than just making holes in sheets. You can manufacture complete parts on a punching machine. Reshaping processes open up new dimensions for you. The versatility of the technology is the result of the wealth of tools used. With appropriate loading and unloading aids, you can even automate your production. For many applications, punching is a true time-saving technology; use punching machines for specific applications to help secure the future success of your company.

Discover the versatility of punching with example parts.

The fascination of punching 4–7

This is how punching has constantly improved.

One technology – many advantages 8–9

Focus on tools, machine concept, and automation.

Pull out all the stops

10–17

The TruPunch machine range.

Our machines in detail

18–29

Find the technical details of all TruPunch machines at a glance.

Technical data

30–31

Our comprehensive services and personal support will give you a competitive advantage.

TruServices.

Your partner in performance

32–33

With TruConnect, you can optimize your value creation process.

The best solution for

your Smart Factory

34

The fascination of punching

From 0 to 1600 in one minute? Only a punching machine can manage that. Within the space of 60 seconds, your punching machine can punch 1600 holes in a sheet. But punching can do far more than that: It can create contours, shape sheets, and transform surfaces. Tapping, embossing, marking, engraving or deburring? With the right tool, your punching machine can become a multipurpose solution.





- **Punch, reshape and insert threads all with one machine**
- **Unbeatably economical for many applications**
- **Part variety thanks to clever tools**



79

**applications provide you
with endless opportunities:**

- 44 standard geometries
- 10 slitting applications
- 20 forming applications
- 5 marking tools
- Bends up to 90°
- 360° tool rotation

1600 strokes in 60 seconds

– only a punching machine can manage that.



142840

different configuration variations are offered even by the simple round punch. This standard tool enables you to modify the diameter, beveled sections, and coatings in almost any combination.

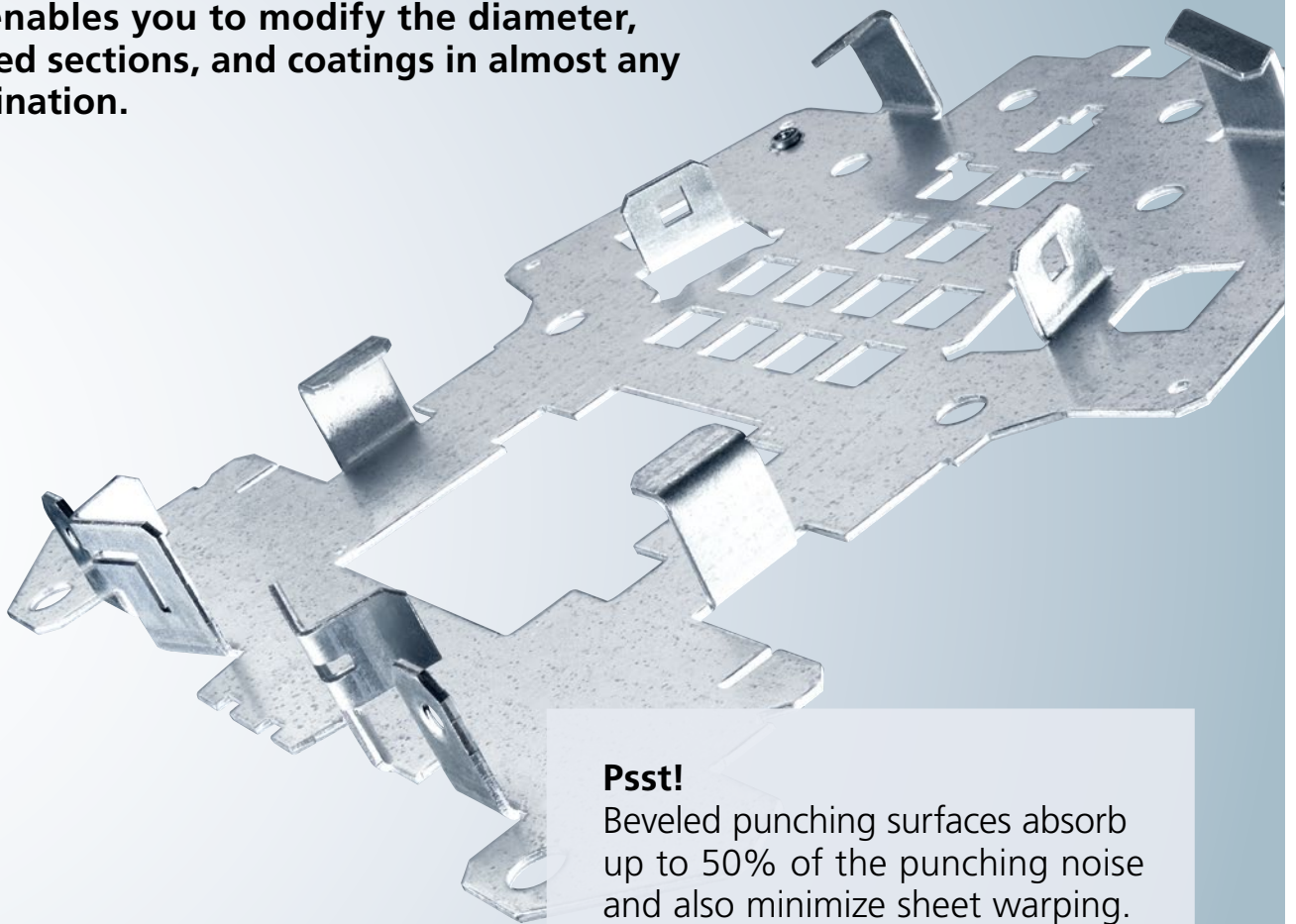

Psst!

Beveled punching surfaces absorb up to 50% of the punching noise and also minimize sheet warping. When you order tools from TRUMPF, these bevels are even available free of charge.



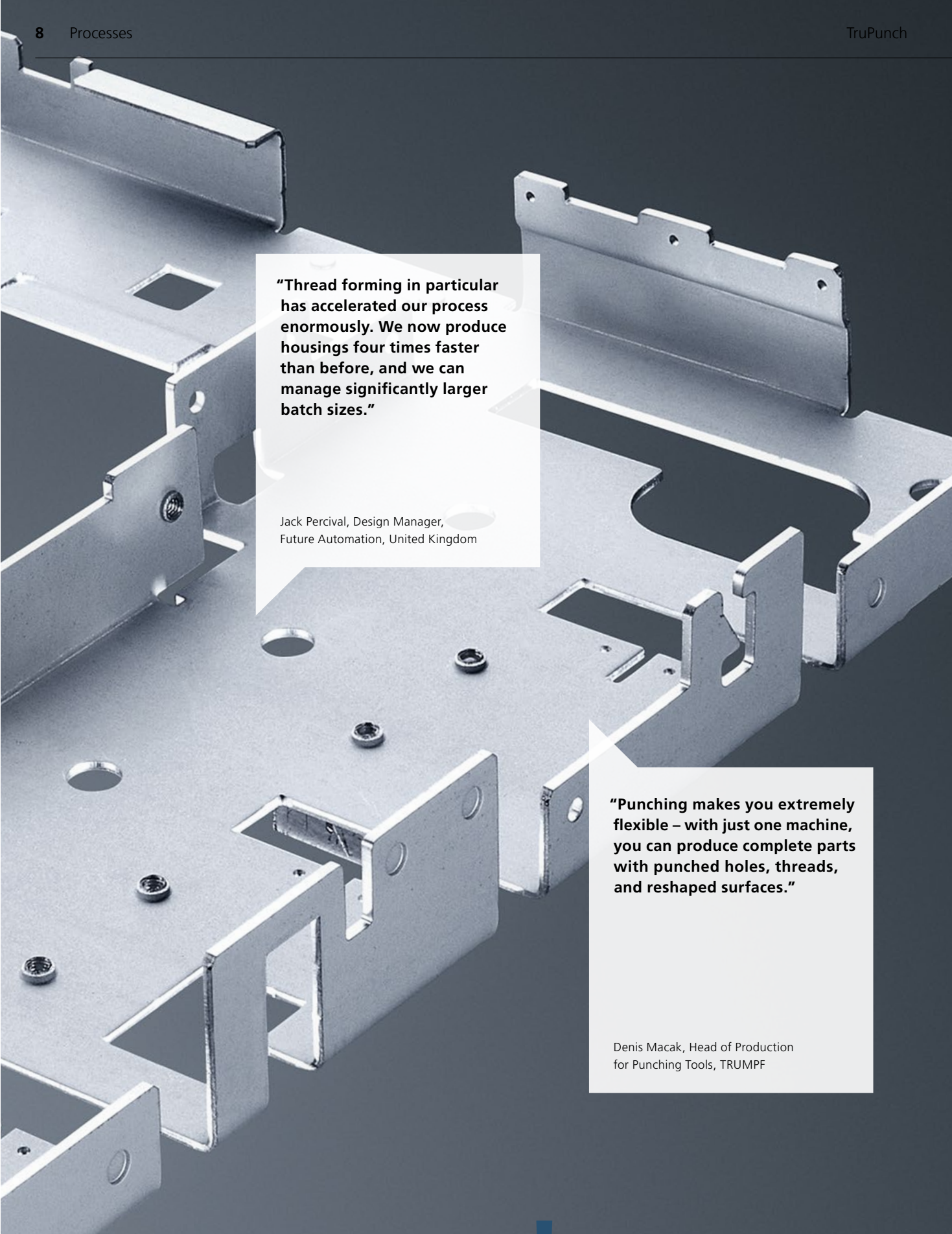

“Thread forming in particular has accelerated our process enormously. We now produce housings four times faster than before, and we can manage significantly larger batch sizes.”

Jack Percival, Design Manager,
Future Automation, United Kingdom

“Punching makes you extremely flexible – with just one machine, you can produce complete parts with punched holes, threads, and reshaped surfaces.”

Denis Macak, Head of Production
for Punching Tools, TRUMPF

Material variety – good to know

With a punching machine you can even process plastics, composites, or wood. We will gladly consult you on this.



One technology – many advantages

Punching technology has constantly improved in recent years: Get ready for new levels of part variety, user-friendliness, and quality. High-quality punching tools now leave virtually no punching burrs behind. Even setup, sorting, and discharge are easier than ever before – this enables you to manufacture even small batch sizes flexibly and cost-effectively.

Geometric perfection

Only a punching machine can achieve geometrically precise shapes to the highest levels of quality – with no seams or spatter and no waves or scratches. This means for example that you can create a perfectly round circle or a perfect square.

Complete processing

Punching, slitting, forming, counter-sinking, tapping, rolling, marking, and deburring: A punching machine is fully capable of performing all of these processing steps. This saves time, as setup and programming only needs to be carried out once. The benefit to you: You can manufacture a wide range of parts entirely on just one machine – and these processes can be fully automated if desired.

Punch faster

If you are producing a number of identical shapes in one go, punching is unbeatably fast and has no competition when it comes to price – TRUMPF punching machines guarantee this with nearly limitless options for slitting, forming, and bending.

➤ Geometric perfection without reworking

➤ Complete processing with just one machine

➤ Unbeatable throughput

Perforated sheets are a classic example:

For this application, punching machines outperform all other technologies in terms of speed and cost-effectiveness.

Find out for yourself with this example:

Perforated plate with 1510 holes, medium format 2500 x 1250 mm, plate thickness of 1 mm, hole diameter of 8 mm

➤ The result:

You can reduce processing time by 76% with a single tool, or by as much as 95% with a MultiTool!

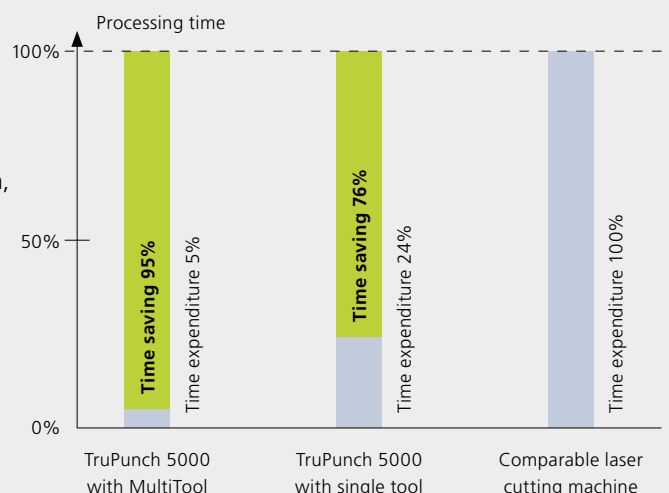



Pull out all the stops

Smaller batch sizes with increasing variance and quality requirements – how can you meet the demands of your customers in future? Modern punching machines from TRUMPF provide you with enormous opportunities: with versatile tools, precise processes, and intelligent automation solutions. Rely on the best punching solution for your future – and get the edge over the competition.





Clever tool concept

With high-quality tools from TRUMPF you can meet any customer wishes. The special thing about it is: The punching head can tilt and turn all tools to any desired angle. All tools can be positioned at any tool station, regardless of their size.

Reliable machine processes

Intelligent functions and a wide range of discharging and sorting options assist you in working on the machine and make your processes smooth and reliable.

Earn more automatically

You can easily automate your TruPunch; a wide range of options are also available for integrating it into existing production systems. Intelligent automation options reduce the workload for the user and increase your throughput.

Short setup times and high productivity

Smooth processes and high machine availability

Lower manpower, higher throughput



Tools: Punching with brains

Whether you need a standard solution or a special solution: With the largest product range on the market, we ensure you can always find the right tool. We manufacture all punching and reshaping tools ourselves, using top-quality steels – to ensure that they meet your highest requirements. Look forward to short delivery times for standard and special tools and a wide range of additional services such as punch beveling at no extra charge.

The right tool for every application

Whether for marking, engraving or deburring: all TRUMPF punching and forming tools are available as standard tools or, if required, as special tools.

You can use our conventional punching tools on TRUMPF punching and punch laser machines of any generation. These tools are particularly durable thanks to their high-quality coating. They are available in a wide variety of shapes and sizes. All you need to use these tools is the RTC universal tool cartridge.

Punching machines can do more than make holes in sheets. Reshaping means punching in the third dimension – producing countersinks, bridges, eyelets, and many more features besides. These tools can also form threads directly into sheets. This can be performed in just one step and is therefore cheaper than using weld nuts or insert nuts.

Thanks to the intelligent punching head and corresponding tool, you can process a huge variety of challenging components entirely on one machine, without even causing burrs if necessary. This can be achieved cost-effectively, even for small quantities – thanks to low tool costs and setup times.

When developing our punching tools, we place a great deal of emphasis on dialog and close collaboration with you. And in the unlikely event that you cannot find a tool that matches your requirements, our specialists will work together with you as a team to develop special tools for your needs. Thanks to our in-house manufacturing and intensive testing, you can rest assured that your new tool will work properly, right from the start.



"I ordered the tool for our new order in the convenient MyTRUMPF e-shop in the morning – and it was shipped the same day."

Uwe Hoffmeister, CEO of B&H Metalltechnik, Deutschland

Clever setup saves time

Your TruPunch machine offers an unbeatable short setup time thanks to its monotool punching head, MultiTools, and tool cartridges.

The fully rotating tool holder also acts as the drive for TRUMPF MultiTool tools. You can integrate up to ten punches in a single MultiTool – this increases the tool capacity of your machine. Each individual tool in the MultiTool can of course be rotated in any direction. This enables you to work more productively and reduce investment costs and setup time.

TRUMPF tool cartridges are made from fiber-reinforced plastic and provide a variety of benefits: Their low weight enables high acceleration values to be achieved on the machine while ensuring that even heavy tools are securely held in place. Thanks to the carrying aid, you can transport three cartridges with one hand. Labeling with colored clips helps you identify cartridges at a glance.

Did you know?

All TRUMPF tools come from our own manufacturing facility. We ship 80% of our tools within 24 hours. You can place orders easily and conveniently in our MyTRUMPF e-shop.



Clever, high-quality tools manufactured in-house:
Punching tools from TRUMPF.
www.trumpf.com/s/imbkg4



“As our customer you can find the perfect machine for your needs that also meets your requirements for power and cost-effectiveness. Every machine offers you a wide range of functions that support you in your day-to-day manufacturing.”

Andreas Kettner-Reich,
Head of Product Management and
Technical Sales Support, TRUMPF

Built for your success

From setup to punching to discharging your parts: TruPunch machines are designed down to the details to provide you with the greatest possible benefits. The result? High-precision, scratch-free parts – even after many years of use.



A worthwhile investment:
Punching machines from TRUMPF.
www.trumpf.com/s/avjtu2





360° punching freedom

An all-rounder instead of a revolver: The monotool punching head can rotate any tool to any desired angle. This reduces material use, the number of tools needed, and setup time.

The freely rotating punching head gives you unrivaled flexibility. The ability to align each tool differently reduces the total amount of tools you need. This reduces your investment costs. The rotational axis in the punching head provides you with full freedom of motion and enables functions such as MultiTool, deburring and rolling technology, as well as thread forming.

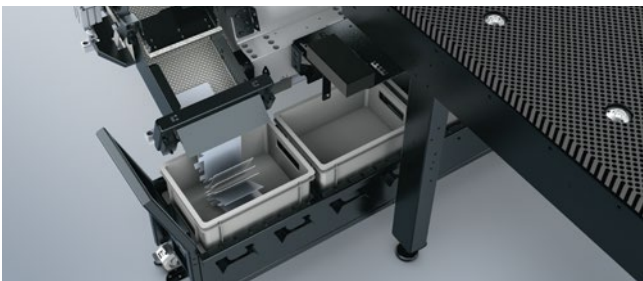

Discharging, unloading and sorting

The discharging and sorting options of TruPunch machines enable your punching production to reach its full potential.

Good parts travel along a chute onto the conveyor belt and from there are transported reliably, safely, and with minimal material wear to the operator, who can remove them without interrupting production. The large parts flap automatically unloads parts up to a format of 400 mm x 600 mm into containers or onto Euro pallets or conveyor belts. Your machine automatically sorts parts up to 180 x 180 mm in size into up to four different boxes.*

* Values apply to the TruPunch 1000 (S19).

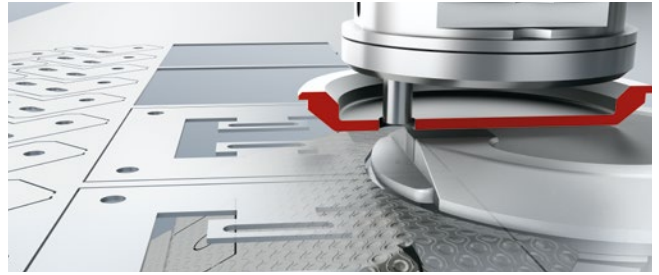

Your machine – your concept

From entry-level processing to high-end operation: what machine concept best suits your needs?

TRUMPF offers customized machine concepts for individual requirements. The hybrid concept of the TruPunch 1000 (S19) has been developed specifically for entry-level users: Sheets are not moved in the Y-direction, minimizing the required installation space. Its electrical drive makes it particularly economical. All other TruPunch machines use the sheetmover principle, where the punching head remains stationary while the sheet moves. Your stamping drive offers large reserves of productivity – ensuring that you are ideally equipped for medium- to high-power operational ranges.

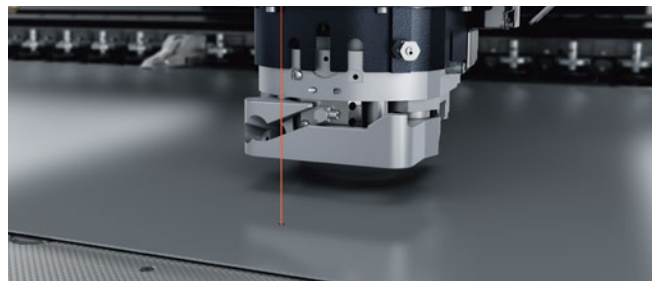

Your machine thinks for itself

Intelligent functions shorten your processes and help you to get the best possible performance from your system.

Thanks to Smart Functions, your machine can detect problems and sometimes even rectify them by itself. For instance, the Smart Punch Monitoring sensors check whether a hole has actually been punched in the sheet prior to tool changing. This enables the machine to detect possible punch breakage and inform the operator. Smart Load helps you to align the sheet on the machine, while Smart Unload monitors discharging. The sheet format detection function compares the actual format to the target format after loading – which helps ensure reliable and safe processes.

Better punching, automatically

When automated, your TruPunch carries out punching operations even more productively – round the clock if necessary. This enables you to work with particular flexibility and ensures that you are ideally prepared for new requirements. Speaking of which: you can retrofit automation components from TRUMPF at any time.

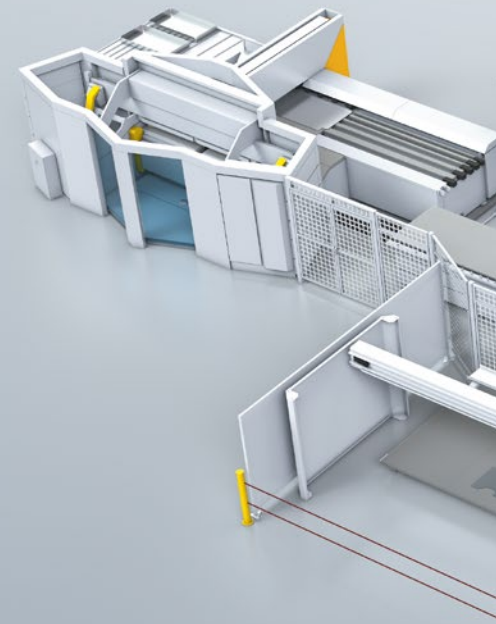

SheetMaster

This component loads and unloads your machine and reliably sorts parts – increasing the service life of your machine.

SheetMaster Compact

Automatically supplies your TruPunch with sheets and unloads grid residue. This enables you to use your machine more effectively.

ToolMaster Linear





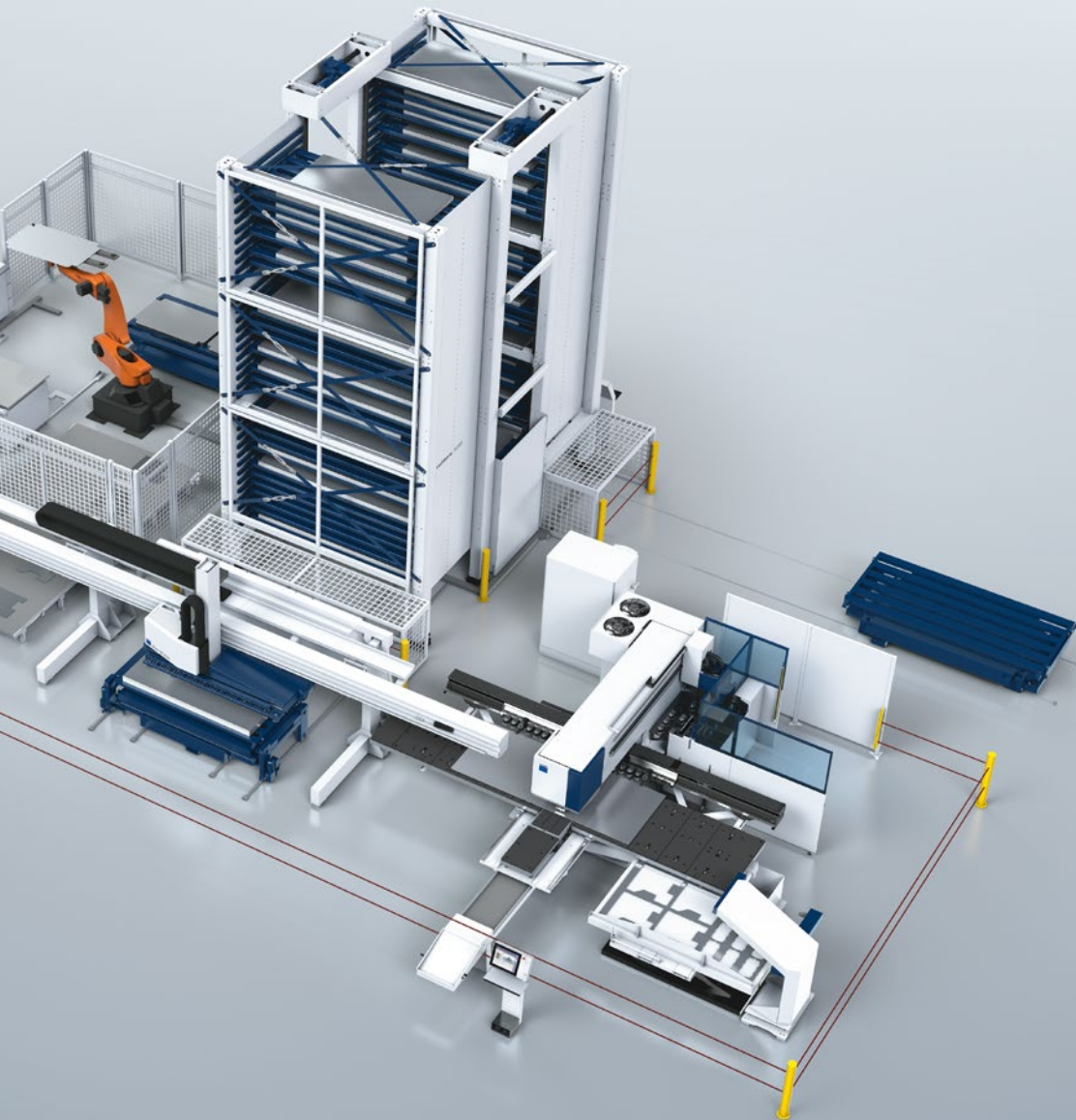

Gain additional tool capacity in order to complete your orders even more quickly.

| Potential machines | SheetMaster | SheetMaster Compact | Cart systems | SortMaster Pallet | SortMaster Box | SortMaster Box Linear |
|---------------------|-----------------------------|---------------------|--------------------|-------------------|----------------|-----------------------|
| Functions | Loading, unloading, sorting | Loading, unloading | Loading, unloading | Sorting | Sorting | Sorting |
| TruPunch 1000 (S05) | | | | | | |
| TruPunch 1000 (S19) | | ■ | | | | |
| TruPunch 2000 | | ■ | | | | |
| TruPunch 3000 | ■ | ■ | ■ | | | ■ |
| TruPunch 5000 | ■ | | ■ | ■ | ■ | ■ |



Automated punching with TRUMPF – save time and money.
www.trumpf.com/s/v114xh

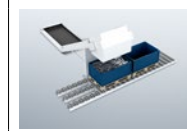

| Integrated sorting function | ToolMaster Linear | GripMaster | ShearMaster | DisposeMaster | TruStore | Stopa |
|---|---|---|---|--|---|---|
|  |  |  |  |  |  |  |
| Sorting | Tool handling | Disposal | Disposal | Disposal | Storage and logistics systems | Storage and logistics systems |
| <input type="checkbox"/> | <input type="checkbox"/> | <input type="checkbox"/> | <input type="checkbox"/> | <input type="checkbox"/> <input type="checkbox"/> | <input type="checkbox"/> <input type="checkbox"/> | <input type="checkbox"/> <input type="checkbox"/> |

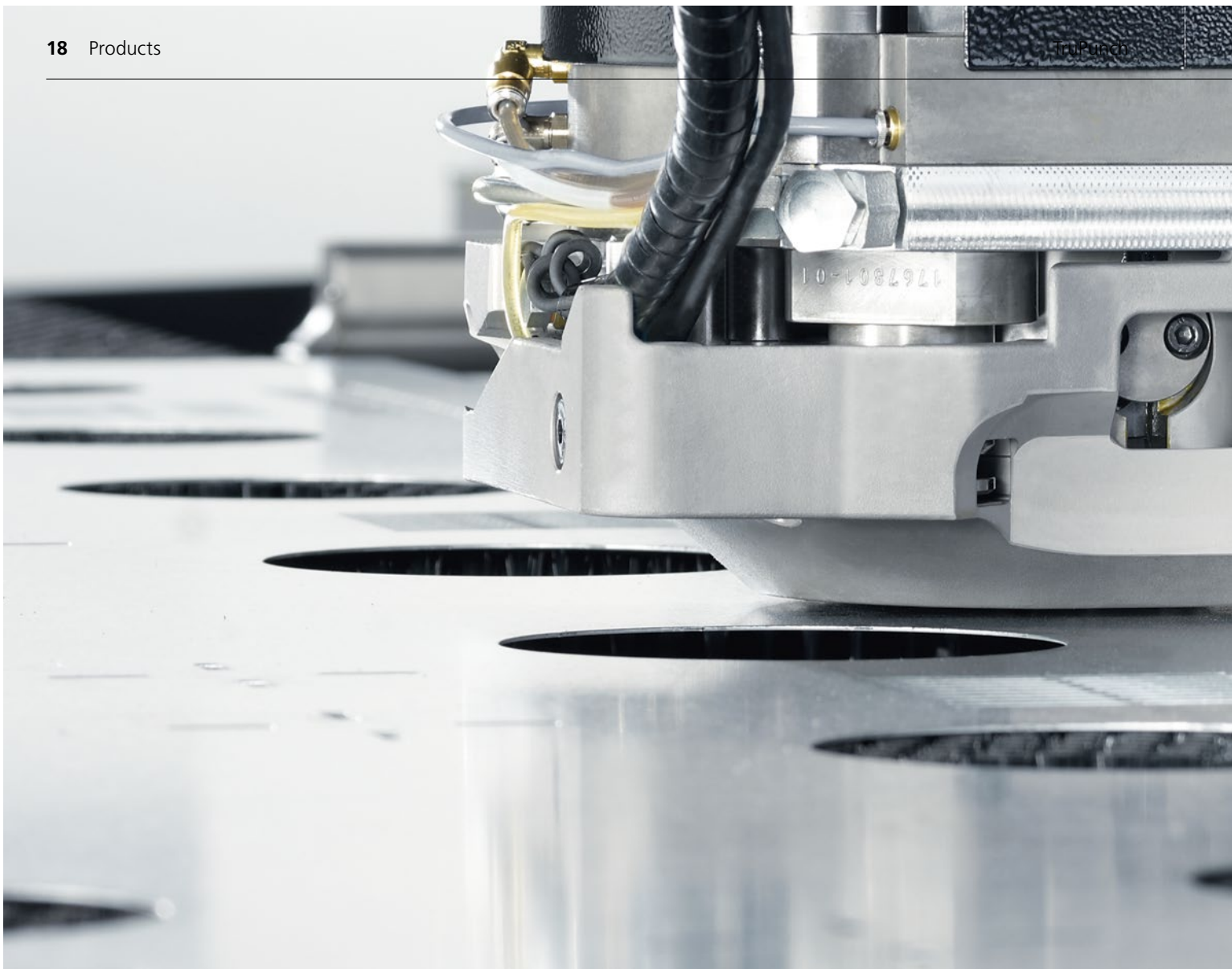

Sure-fire success

The choice is yours – in every productivity class: From the cost-effective TruPunch 1000 entry-level machine to the compact TruPunch 2000 and the resource-efficient TruPunch 3000 universal machine through to the productive TruPunch 5000 high-end machine. Which one suits your requirements?



| | TruPunch 1000 (S05) | TruPunch 1000 (S19) | TruPunch 2000 | TruPunch 3000 | TruPunch 5000 |
|------------------------|---------------------|---------------------|---------------|---------------|---------------|
| Sheet thickness | 6.4 mm | | | | 8 mm |
| Format | Small format | Medium format | | | Large format |
| | | Large format | | Large format | |
| Productivity | + | +++ | ++ | ++++ | +++++ |
| Automation | No | Yes | Yes | Yes | Yes |



You can also find the right machine for your requirements online: www.trumpf.com/s/avjtu2



TruPunch 1000 (S05)

A machine for cost-effective entry into professional punch processing – versatile, compact, and easy to operate.

01

Versatile
punching

04

Manufacture
high-quality parts

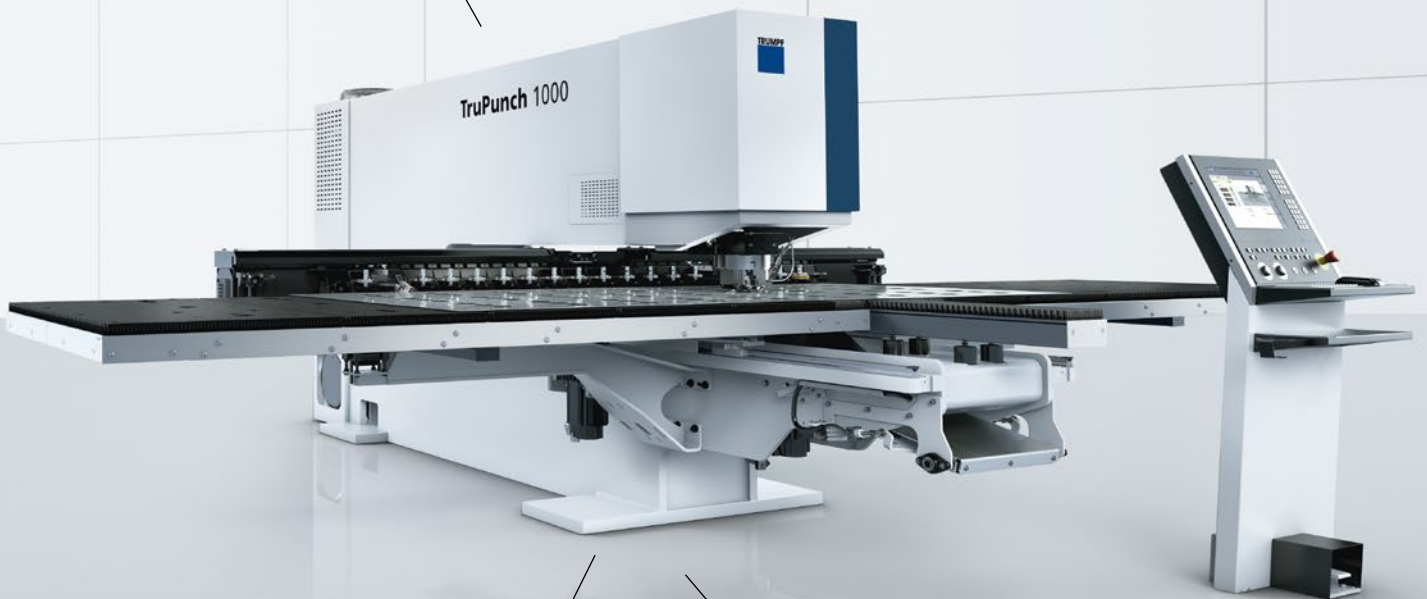

02

Cost-effective
even at low capacity

03

Easy
operation

01

Versatile

punching

Punching, forming, tapping, marking, engraving, deburring: The TruPunch 1000 (S05) can flexibly handle all processing variants – and in sheet thicknesses of up to 6.4 mm. Get ready for full 360° tool rotation and access to the entire TRUMPF punching expertise.



The punching head can rotate any tool to any desired position.

02

Cost-effective

even at low capacity

This machine features low investment and operating costs. You can manufacture even small jobs and batch sizes cost-effectively, quickly, and flexibly.

03

Easy

operation

Thanks to the user-friendly control system, you can manufacture both simple and complex parts in a very short time. Even beginners can operate this machine reliably and safely. This is ensured by the clear touchscreen display, the ergonomic control panel, and the intuitive menu guidance.



Simply intuitive: Control via touchscreen.

04

Manufacture

high-quality parts

The tried-and-tested machine concept guarantees you a high and consistent level of precision – the ideal basis for high part quality.



For more information about
the TruPunch 1000 (S05):
www.trumpf.com/s/9xcl3d



TruPunch 1000

 (S19)

The new TruPunch 1000 (S19) is radically different. Its automation options are unparalleled in its class. And the best part is that, in line with the development of your business, you can upgrade this machine into an equally compact punch laser production cell.

01

Innovative

thanks to patented Delta Drive

04

Top of its class

in discharging and sorting options

02

Saves space

by using 15% less floor space than the previous model

03

Secure for the future

through growing machine concept



01

Innovative

thanks to patented Delta Drive

Compact and dynamic – the drive has been completely redesigned by our developers. The patented Delta Drive makes it unnecessary to move the plate and supporting table in the Y-axis, as for the first time it enables the punching head to move back and forth, or to “fly”. This is made possible by a sophisticated drive system.

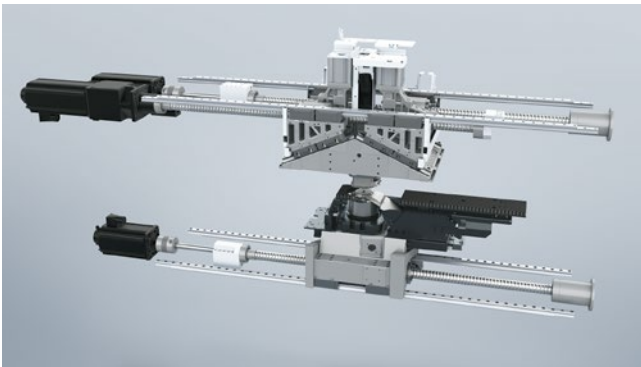

Delta Drive: This innovative drive concept offers novel processing and discharging options.

02

Saves space

by using 15% less floor space than the previous model

With the TruPunch 1000 (S19), you can reduce the space you need for installation by up to 15%. It remains compact even after automation of the loading and unloading processes SheetMaster Compact: the parts containers are arranged to be space-neutral.

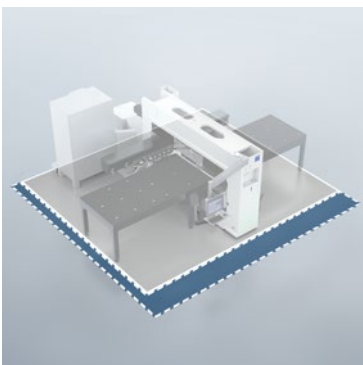

The TruPunch 1000 (S19) requires 15% less space than the previous model.

03

Secure for the future

through growing machine concept

Pave the way for your success: With the first modular machine concept for punching and laser cutting in the world, you are always able to react flexibly to changing order situations. You grow – and your machine grows with you.



By retrofitting the laser and adding additional components, the TruPunch 1000 (S19) can be converted into the TruMatic 1000 fiber.

04

Top of its class

in discharging and sorting options

The large parts flap enables you to automate the unloading of parts with a format of up to 400 mm x 600 mm. Conveyor belts transport the parts to the correct container. The machine automatically sorts good parts with sizes of up to 180 x 180 mm into waiting containers.



The large parts flap enables you to sort parts reliably and safely.



For more information about the TruPunch 1000 (S19): www.trumpf.com/s/xelum42



TruPunch 2000

The compact TruPunch 2000 paves the way for you to begin using automated punching processes. It works highly productive to process a wide range of parts to the highest levels of quality.

01

Ergonomic

through clever operation

04

Helpful

thanks to numerous functions



02

Cost-effective

through clever hydraulics

03

Automated

for more productive work

01

Ergonomic

through clever operation

The ergonomic control panel ensures easy and convenient operation of the machine. All functions are available quickly and you can select them directly. The machine can be controlled via icons using a touchscreen, and the number of selection fields is reduced to a minimum.



Operation via touchscreen is extremely simple.

02

Cost-effective

through clever hydraulics

Thanks to the On-Demand Drive, the punching head hydraulics are always working at the ideal level – reducing operating costs and saving resources. The lower strain on the hydraulics helps prevent wear on your machine and reduces maintenance and repair costs.



Powerful and energy-efficient: Intelligent punching drives from TRUMPF.

03

Automated

for more productive work

Use the automation options for your TruPunch 2000 – with the SheetMaster Compact, you can get started with automated manufacturing with a compact and inexpensive solution.



Compact and saves space: The SheetMaster Compact loads blank sheets and unloads microjoint sheets and grid residue.

04

Helpful

thanks to numerous functions

If valuable support is appealing for your operations, brush beds reduce wear on your material and prevent scratches. The unloading aid supports the operator, while processing with no grid residue saves material.

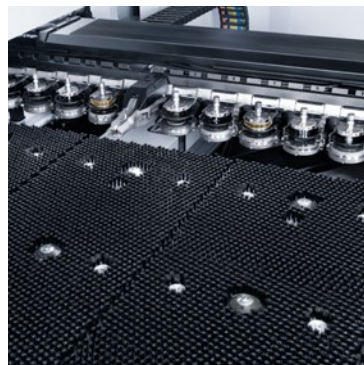

For processing with minimal wear on the material, select the brush bed option.



For more information about the TruPunch 2000: www.trumpf.com/s/7ywi38



TruPunch 3000

Thanks to processing with no grid residue, this resource-saving universal machine reduces material consumption by an average of 10% and is particularly energy-efficient in operation.

01

Energy-efficient
punching

04

No grid residue
for threefold benefits



02

Minimal material wear
thanks to retractable die

03

Intelligent
with automatic part sorting

01

Energy-efficient

punching

With its electrical punching head and an average power consumption of just 4.5 kW, the TruPunch 3000 is highly energy-efficient in operation. Its power consumption in standby mode is also low, and it is equipped with an energy recovery system.



The electrical punching head saves resources.

02

Minimal material wear

thanks to retractable die

The retractable die enables punching and reshaping operations with minimal scratches and eliminates the risk of parts getting caught. Brush beds and brushable part flaps also contribute to part quality.

03

Intelligent

with automatic part sorting

The sorting flap separates good and scrap parts quickly and automatically. Processing by rows also reduces your processing time. The SortMaster Box sorts your good parts into inexpensive standard boxes, while the DisposeMaster differentiates between up to three types of waste and unloads it into scrap containers.

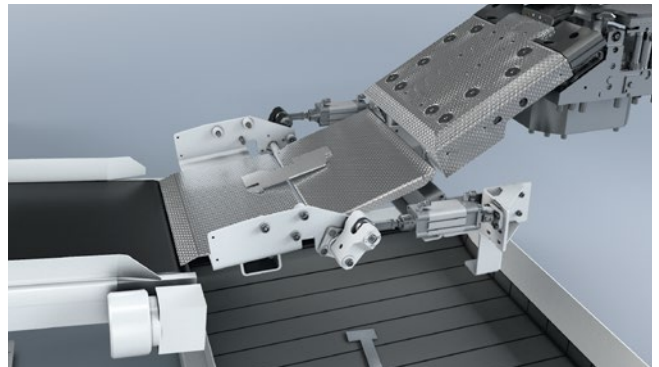

The sorting diverter reliably separates good and scrap parts.

04

No grid residue

for threefold benefits

Punching with no grid residue is particularly reliable, saves material, and reduces the effort for the operator. Grid residue cannot get caught as it is automatically broken up and discharged. Common separating cuts enable you to increase utilization of each sheet by an average of 10%. The sorting flap separates good parts from sheet residue and distributes them flexibly into any desired container.

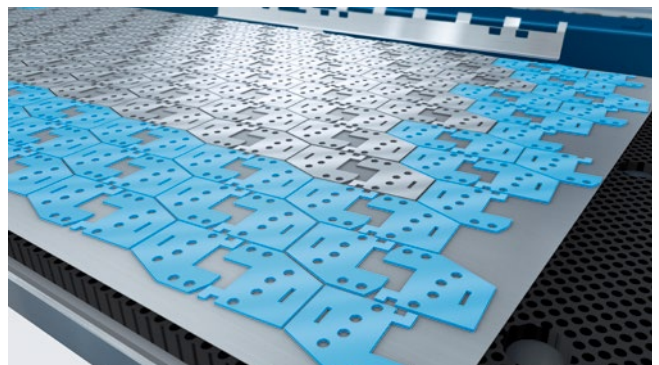

Thanks to processing with no grid residue, you can get more out of your sheets.



For more information about
the TruPunch 3000:
www.trumpf.com/s/yzkqmo



TruPunch 5000

This high-end machine sets new standards: it is highly productive with maximum axis dynamics, and can flexibly provide the best possible part quality thanks to its retractable clamping claws and active die.

01

Turbo drive

reaches 1600 strokes/minute

04

Rapid tool change

with ToolMaster Linear

02

Quality and flexibility

thanks to the active die

03

Material efficiency

thanks to retractable clamping claws



01

Turbo drive

reaches 1600 strokes/minute

Thanks to the powerful hydraulic drive, you can carry out stamping operations at up to 1600 strokes per minute and etching operations at 2800 strokes per minute. Drives with zero play enable maximum axis acceleration. The high rotational speed of the C-axis enables you to carry out tapping extremely rapidly and to productively process complex contours.

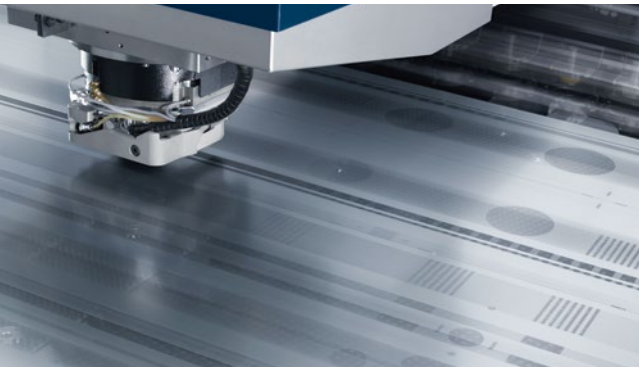

Maximum performance: The TruPunch 5000 is the fastest punching machine in the world.

02

Quality and flexibility

thanks to the active die

The reshaping die can be retracted for scratch-free processing. You can use reshaping tools with a minimum circumscribed circle of up to 100 mm and process your parts from below thanks to the active stroke axis.

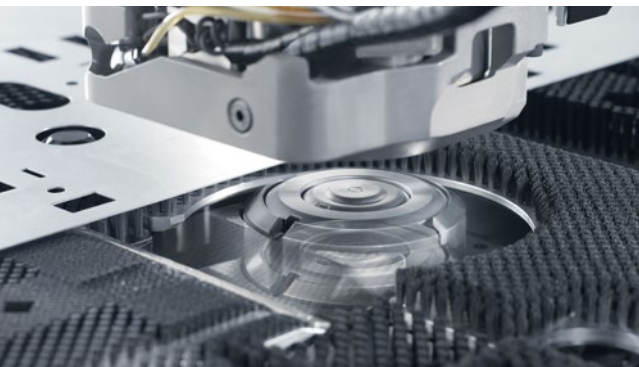

The active die provides for active reshaping from below and enables scratch-free processing.

03

Material efficiency

thanks to retractable clamping claws

Retractable clamping claws ensure maximum part quality and precision. You can improve your material efficiency by using the protective areas when loading panels. This makes it usually unnecessary to change over the claws, increasing your productivity.

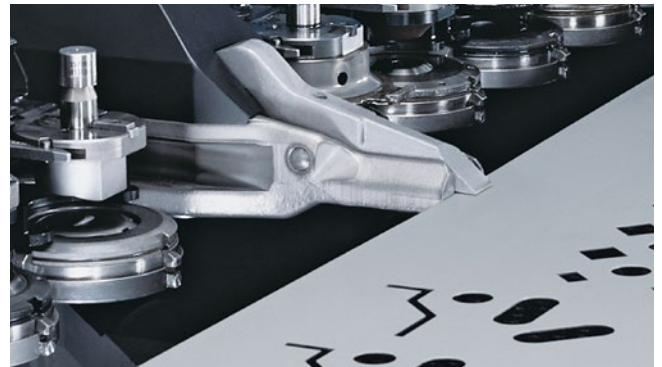

Retractable clamping claws ensure maximum utilization of each sheet.

04

Rapid tool change

with ToolMaster Linear

The ToolMaster Linear enables you to benefit from shorter processing times and a capacity of 18, 54 or 90 tool stations with the option for modular expansion. This provides you with exceptional flexibility for your punching operations – including automatic processing round the clock.

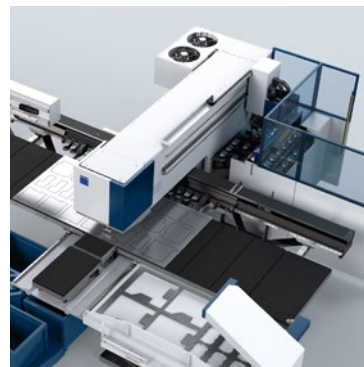

Automatic tool change with the ToolMaster Linear.



For more information about
the TruPunch 5000:
www.trumpf.com/s/rbwhgq



Technical data

These pages provide you with a summary of the technical data of the TruPunch machines:

| Technical data | | | | | |
|---|-------|---------------------|---------------|---------------------|--------------|
| | | TruPunch 1000 (S05) | | TruPunch 1000 (S19) | |
| | | Small format | Medium format | Medium format | Large format |
| Working area | mm | 2050 x 1250 | 2500 x 1250 | 2500 x 1250 | 3050 x 1525 |
| Max. sheet thickness | mm | 6.4 | 6.4 | 6.4 | 6.4 |
| Max. effective punching force* | kN | 165 | 165 | 165 | 165 |
| Axis speed (X and Y simultaneously) | m/min | 97 | 97 | 100 | 100 |
| Max. punching stroke rate (E = 1 mm) | 1/min | 600 | 600 | 600 | 600 |
| Tools / with number of claws | Items | 15/ 2 | 18/ 2 | 18/ 2 | 21/ 3 |
| Tool change time for single tool | s | 4.4 | 4.4 | 3.2 | 3.2 |
| Tool change time | s | 2.4 | 2.4 | 2.4 | 2.4 |
| Positioning deviation | mm | 0.1 | 0.1 | 0.1 | 0.1 |
| Part discharge: Max. part size | mm | 180 x 150 | 180 x 150 | 400 x 1250* | 400 x 1250* |
| Part discharge: Max. part size with sliding table | mm | 460 x 500 | 460 x 500 | – | – |
| Space requirements | mm | 6000 x 7144 | 6550 x 7144 | 6500 x 5100 | 7650 x 7670 |
| Average power consumption during production | kW | 4.3 | 4.3 | 3.5 | 3.5 |

* Reliable discharge up to maximum part size of 400 mm x 600 mm.
Subject to changes. The specifications given in our quotation and our order confirmation apply.

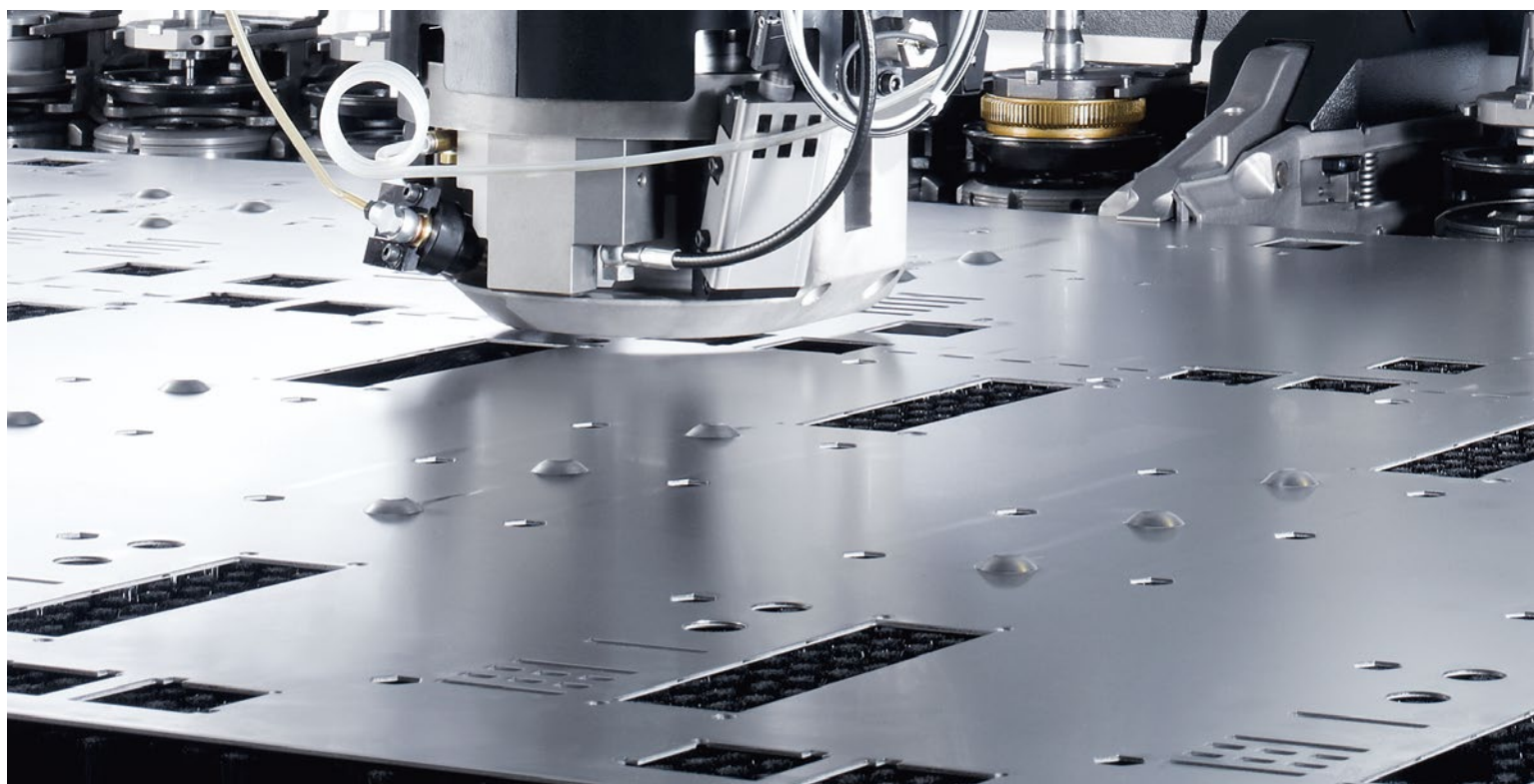

| TruPunch 2000 | TruPunch 3000 | | TruPunch 5000 | |
|---------------|---------------|--------------|---------------|--------------|
| Medium format | Medium format | Large format | Medium format | Large format |
| 2500 x 1250 | 2500 x 1250 | 3050 x 1525 | 2500 x 1250 | 3050 x 1550 |
| 6.4 | 6.4 | 6.4 | 8 | 8 |
| 165 | 180 | 180 | 220 | 220 |
| 108 | 108 | 108 | 116 | 116 |
| 900 | 1000 | 800 | 1600 | 1350 |
| 18 / 2 | 18 / 2 | 21 / 3 | 18 / 3 | 21 / 4 |
| 4 | 3.1 | 3.1 | 2.8 | 2.8 |
| 2.2 | 0.3 | 0.3 | 0.3 | 0.3 |
| 0.1 | 0.1 | 0.1 | 0.1 | 0.1 |
| 180 x 150 | 500 x 500 | 500 x 500 | 500 x 500 | 500 x 500 |
| 460 x 500 | – | – | – | – |
| 6540 x 5837 | 5000 x 6500 | 5800 x 7650 | 6760 x 6100 | 7600 x 7000 |
| 4.5 | 4.5 | 4.5 | 9.5 | 9.5 |



100% effective punching force

The effective punching force is the force that is effectively applied to your sheet. Thanks to the TRUMPF concept, the value for this is 100%. Contrary to the effective punching force, the often cited initial force that a tool applies to the punching head is less significant because, depending on the tool path, a lesser or greater proportion of the force is lost. It is therefore better to rely on the effective punching force – as that is what actually matters.

TruServices. Your partner in performance

To secure your future success, capitalize on services that will move you forward not just short-term but in the long run, too: Whether you want to create the best conditions for successful manufacturing, make the most of your TRUMPF punching machines, or have the flexibility to adapt them to changing requirements – together we will find opportunities to maximize your value creation long-term. We will provide you with all-round support as a reliable partner with solutions and service packages for your needs – enabling you to manufacture economically and at a constantly high level.



Comprehensive training program

EMPOWER: If you wish to create the best conditions for successful manufacturing: We will support you in this. Use our comprehensive training program in order to develop your skills and gain competitive advantages. Having the appropriate training enables you, for example, to program your punching machine more quickly.

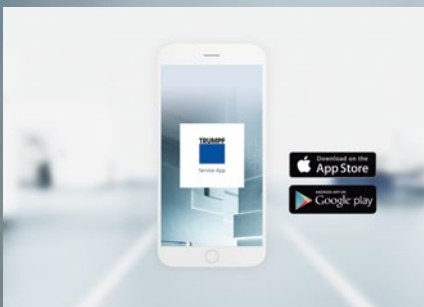

Technical Service

SUPPORT: If flexibility and availability of equipment in day-to-day operations are essential to you: We are there for you. Our technical customer service team and the TRUMPF service network will support you. You can get in touch with us very easily, even via app.



Part design consultation

IMPROVE: If you want to gradually focus your manufacturing on maximum value creation: We will work together to reach your goal. Part design consultation, for instance, enables you to find out how you can reduce your manufacturing costs by up to 60% thanks to smarter sheet designs. What would you like to improve?



- | | | |
|---------------------------------|----------------------|-----------------------|
| Financing | Training | Pre-owned Machines |
| Technical Service | Tools | Genuine Parts |
| Design and Programming Software | Process Optimization | Monitoring & Analysis |
| Product Enhancements | Value Packages | Service Agreements |



You can learn more about our complete and comprehensive package of useful services here: www.trumpf.com/s/services



The best solution for your Smart Factory

Industry 4.0 is changing our professional world. How can you react to this increasing complexity in your production facility? With TruConnect, you can optimize your entire value creation process, step by step, by networking your production facility both digitally and physically: from software to machines and services through to automation, storage, and logistics systems. Talk to us about the best production solution for your Smart Factory. You can find two example cases here:

Your requirement:

The solution:

Advantages for you:



Discover the modular networking solutions from TRUMPF with TruConnect.
www.trumpf.com/s/smart-factory



Punching and bending production lines with coil connection

A direct chain from the coil to the bent sheet using "one piece flow".

Combine your coil system, punching machine, and bending brake.

- No need to program the coil system
- Coil system communicates with the punching machine as an external loading unit
- Machines can be used within the chain as well as individually
- Buffers compensate for different machine cycle times (for example, use of a BendMaster for the bending brake)

Automation of oversize format parts

You want to load sheets up to 4000 x 1500 mm fully automatically, load sheet formats and finished parts in the same dimensions automatically, and unload sorted parts and automatically dispose of grid residue up to 4000 x 1500 mm.

You can for instance combine a TruPunch 5000 and a LiftMaster.

- You enjoy increased flexibility in your production facility
- You can adjust your production facility to suit different sheet formats in no time at all
- You can easily master short job changes and small batch sizes

The passion that drives us

From production and manufacturing technology to laser systems and material processing, we develop highly innovative products and services to meet your needs. Our solutions are superbly reliable and ready for industrial use. We do everything we can to give you a powerful competitive edge, drawing on our expertise, experience, and a genuine passion for what we do.



Check out our
YouTube page:
[www.youtube.com/
TRUMPFtube](http://www.youtube.com/TRUMPFtube)

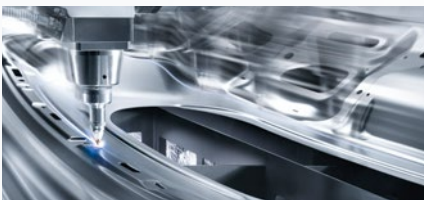

Lasers for manufacturing technology

Whether macro, micro or nano: We have the right laser and the right technology for any industrial application, allowing you to manufacture in an innovative yet cost-efficient manner. As well as the technology, we will also support you with system solutions, knowledge of applications, and advice.



Power-supply systems for high-tech processes

From semi-conductor production to manufacturing solar cells: Our high- and medium-frequency generators give electricity for induction heating, plasma and laser excitation a defined form based on frequency and demand – highly reliable and for repeat accuracy.



Machine tools for flexible sheet metal and pipe work

Laser cutting, punching, bending, laser welding: For all processes in flexible sheet production, we offer you custom-fit machines and automation solutions, including consultancy, software, and services – enabling you to produce your products reliably and in high quality.



Industry 4.0

The TruConnect range of solutions connects man and machine through information. It covers all steps of the production process – from offer to shipping your parts.

TRUMPF is certified to ISO 9001
(Find out more: www.trumpf.com/s/quality)



TRUMPF Werkzeugmaschinen GmbH + Co. KG
www.trumpf.com